

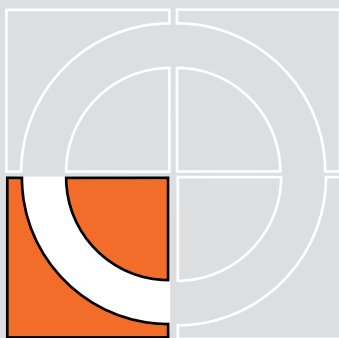

**ENGANCHES**  
**ARAGON**

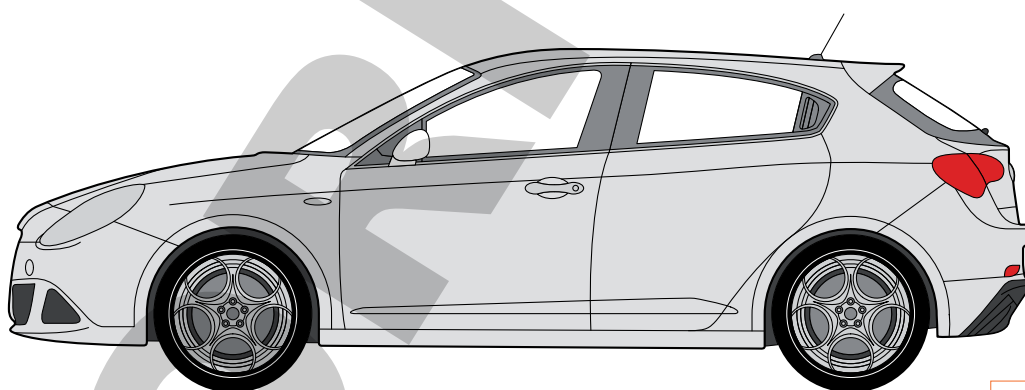

ALFA ROMEO GIULIETTA 2010



Nº Revisión | Fecha Aprobación

Nº 001 | 17-11-2010

**E**

Enganches Aragón ofrece una garantía de sus productos por un período de dos años a partir de la fecha de entrega conforme a lo dispuesto en la Directiva 1999/44/CE y la ley 23/2003 quedando limitada al reemplazo de la mercancía defectuosa y en ningún caso se extenderá a daños o perjuicios consecuenciales.

Enganche fabricado por ENGANCHES ARAGON adaptable a la marca del vehículo.

Queda formalmente prohibido cualquier tipo de modificación, transformación o alteración sobre cualquiera de nuestros productos. El incumplimiento de esto daría lugar inmediatamente a la anulación de la homologación y de la garantía del producto.

**GB**

Enganches Aragon offers a two years guarantee of their products from the delivery date according to arranged in the european directive 1999/44/CE and law 23/2003 being limited to the replacement of faulty products and in no case will be extended to damages or consequent harms.

Towbar made by ENGANCHES ARAGON adaptable to the brand of the vehicle.

It is forbidden to make any modification to our towbars. The breach of this condition will cancel the approval and the guarantee product.

**F**

Enganches Aragón offre une garantie de ses produits pour une période de deux années à partir de la date de livraison conformément à ce qu'est disposé dans la directive 1999/44/CE ainsi que la loi 23/2003 en étant limitée au remplacement de la marchandise défectueuse et dans aucun cas il sera étendu des dommages et intérêts.

Attelage fabriqué par ENGANCHES ARAGON adaptable à la marque de ce véhicule.

Il est interdit de faire des modifications ou transformations sur les attelages. Le Non-respect de cela donnera lieu à l'immédiate annulation de l'homologation et de la garantie du produit.

**I**

Enganches y remolques Enganches Aragon offre una garanzia dei suoi prodotti entro un periodo di due anni dalla data della consegna conforme alla direttiva 1999/44/CE e la legge 23/2003 che è limitata alla sostituzione della merce difettosa ed in nessun caso si estenderà ai danni o ai pregiudizi conseguenti.

Dispositivo di traino ENGANCHES ARAGON adeguato alla marca di questo veicolo.

È totalmente proibito effettuare qualsiasi tipo di modifica (fori addizionali, saldare pezzi, togliere pezzi, ecc.) sui ganci. L'inadempienza di questa condizione provoca l'annullamento della garanzia e dell'omologazione del gancio.

**D**

Enganches Aragon bietet eine garantie seiner Produkte gültig für 2 jahre ab dem Abgabedatum nach der europäischen Rechtlinie 1999/44/CE und dem Gesetz 23/2003 an. Die Garantie ist gültig für die Ersetzung der defekten Waren und auf keinen fall für die Schäden oder nachfolgenden Beschädigungen.

Für dieses Fahrzeug angepasst und hergestellt durch ENGANCHES ARAGON

Es ist strikt verboten, an den Kupplungen jegliche Veränderung (zusätzliche Löcher, Anschweißen von Teilen, Entfernung von Teilen) vorzunehmen. Die Nichteinhaltung dieser Bedingung hat die Ungültigkeit der Garantie und der Genehmigung der Kupplung zur Folge.

**NL**

Enganches Aragon biedt een termijn van twee jaar garantie aan op haar producten vanaf de leveringsdatum overeenkomstig de afspraken in het Europese directief 1999/44/CE en wet 23/2003. De garantie beperkt zich specifiek tot het vervangen van foutief geleverde producten en zal in geen enkel geval uitgebreid worden bij schade of blijvend letsel.

Trekhaak welke geproduceerd zijn door ENGANCHES ARAGON zijn alleen te gebruiken voor het merk en type van het opgegeven voertuig.

Het is absoluut verboden om onze trekhaak, op welke manier dan ook, te modificeren. Indien aan deze conditie geen gevolg gegeven wordt vervalt de wettelijke type goedkeuring en daarmee de garantie op het product



Homologation  
EC/94/20

# ALFA ROMEO GIULIETTA 2010



| Model    | CLASS  | APPROVAL NUMBER | TYPE     | D-VALUE (kN) | MAX. VERT. LOAD (kg) |
|----------|--------|-----------------|----------|--------------|----------------------|
| ALF003   | A 50-X | e 13 00-3341    | ALF003   | 8,62         | 90                   |
| ALF004-S | A 50-X | e 13 00-3342    | ALF004-S | 8,62         | 90                   |
| ALF004-V | A 50-X | e 13 00-3342    | ALF004-V | 8,62         | 90                   |
| ALF004-A | A 50-X | e 13 00-3342    | ALF004-A | 8,62         | 90                   |

Tel: +34 976 45 71 30  
www.enganchesaragon.com

T = 1600 kg

D = 8,62 kN

S = 90 kg

C (kg)      T (kg)

$g = 9,81 \text{ m/s}^2$









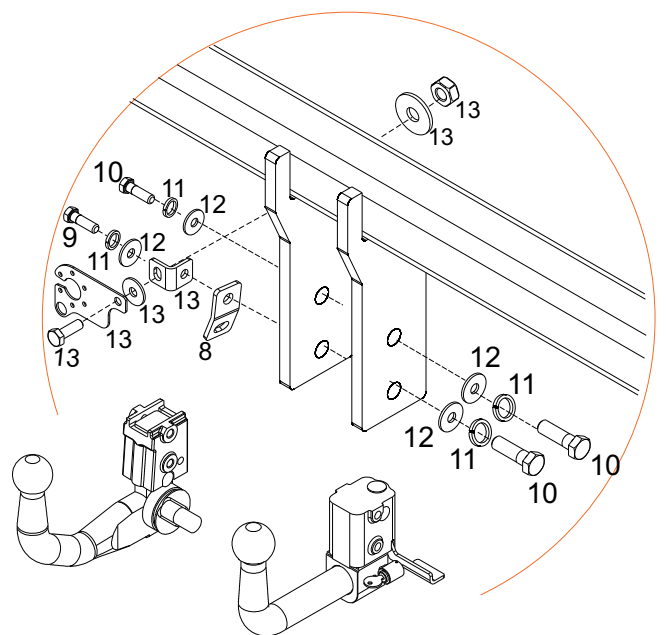
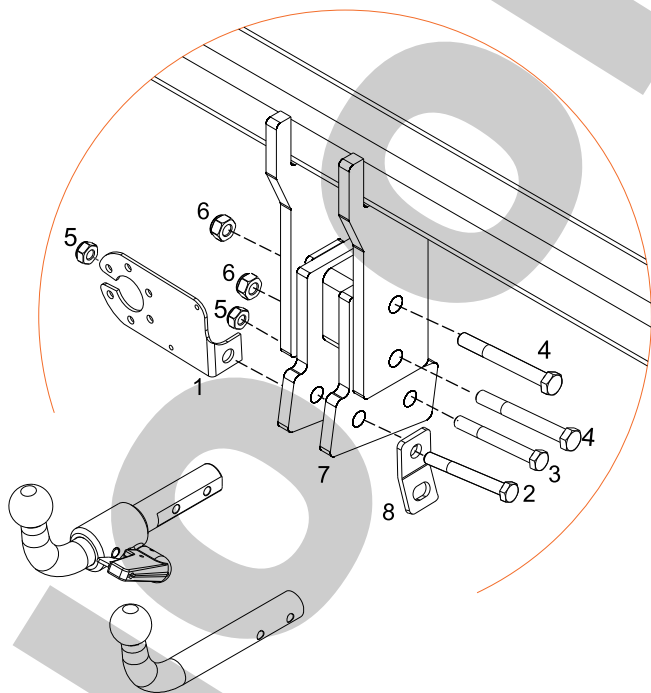
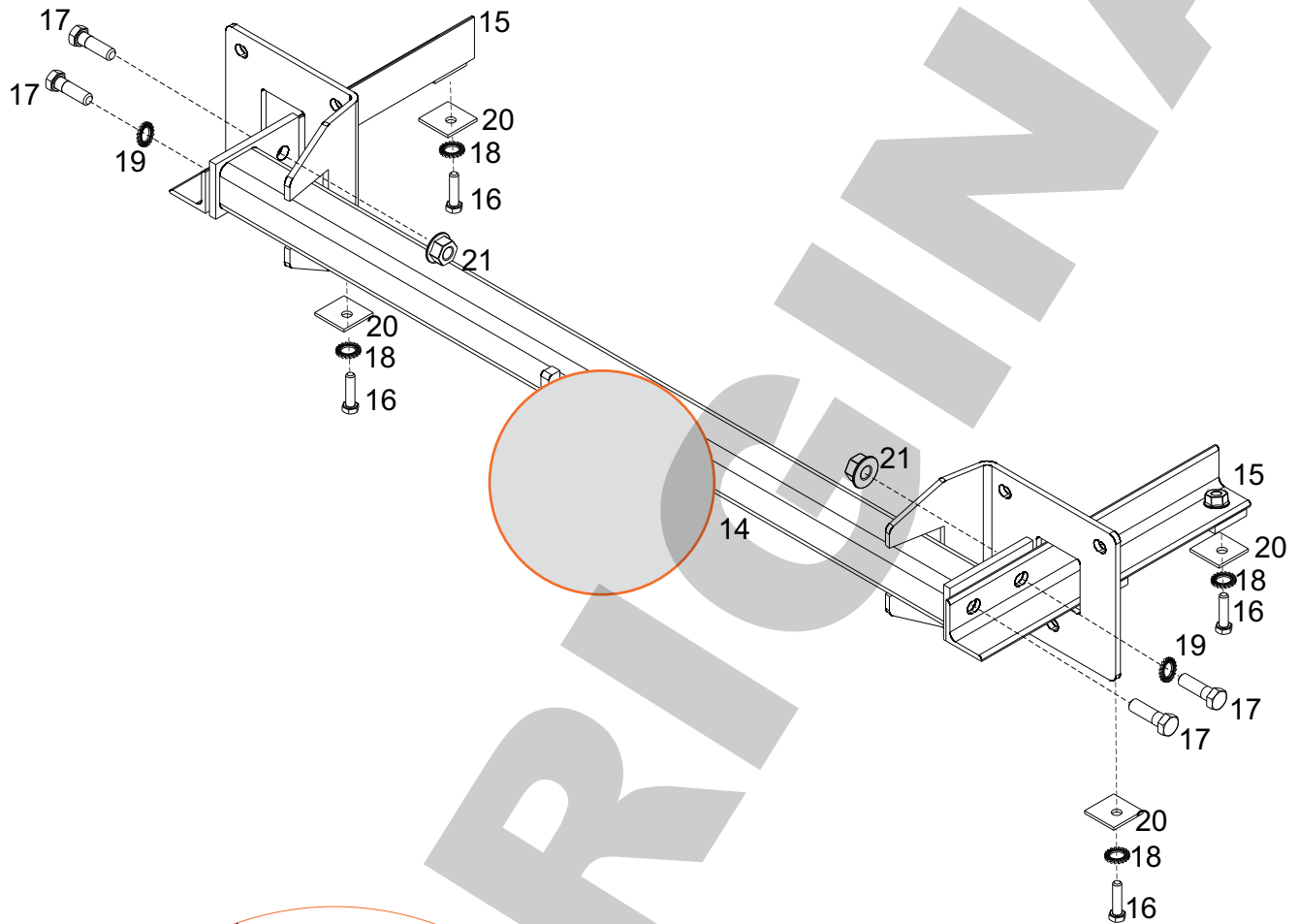

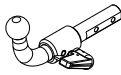

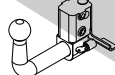











$$D \geq \frac{T \cdot C}{T+C} \cdot \frac{g}{1000} \text{ (kN)}$$

$$T \leq \frac{C \cdot D \cdot 1000}{(C \cdot g) - (1000 \cdot D)} \text{ (kg)}$$

|     |    |     |     |     |     |
|-----|----|-----|-----|-----|-----|
|     | M8 | M10 | M12 | M14 | M16 |
| N/m | 25 | 55  | 85  | 135 | 200 |

0 km      1000 km



|    |   |                        |   |  |   |   |
|----|---|------------------------|---|--|---|---|
|    |   |                        |  |  |  |  |
| 1  |    |                        |   | 1  |   |   |
| 2  |    | M10 x 70 DIN 931(8.8)  |   | 1  |   |   |
| 3  |    | M10 x 65 DIN 931(8.8)  |   | 1  |   |   |
| 4  |    | M12 x 100 DIN 931(8.8) |   | 2  |   |   |
| 5  |    | M10 DIN 985            |   | 2  |   |   |
| 6  |    | M12 DIN 985            |   | 2  |   |   |
| 7  |    | AEA00N0                |   | 1  |   |   |
| 8  |    |                        |   |  | 1   |   |
| 9  |    | M12 x 35 DIN 933 (8.8) |   |  |   | 1   |
| 10 |    | M12 x 25 DIN 933 (8.8) |   |  |   | 4   |
| 11 |  | M12 DIN 128            |   |  |   | 4   |
| 12 |  | M12 DIN 125            |   |  |   | 4   |
| 13 |  |                        |   |  |   | 1   |
| 14 |  |                        |   |  | 1   |   |
| 15 |  |                        |   |  | 1+1   |   |
| 16 |  | M10 x 35 DIN 933 (8.8) |   |  | 4   |   |
| 17 |  | M12 x 40 DIN 933 (8.8) |   |  | 4   |   |
| 18 |  | ø10 DIN 6798           |   |  | 4   |   |
| 19 |  | ø12 DIN 6798           |   |  | 2   |   |
| 20 |  | 50x50                  |   |  | 4   |   |
| 21 |  | M12 DIN 934            |   |  | 2   |   |



1

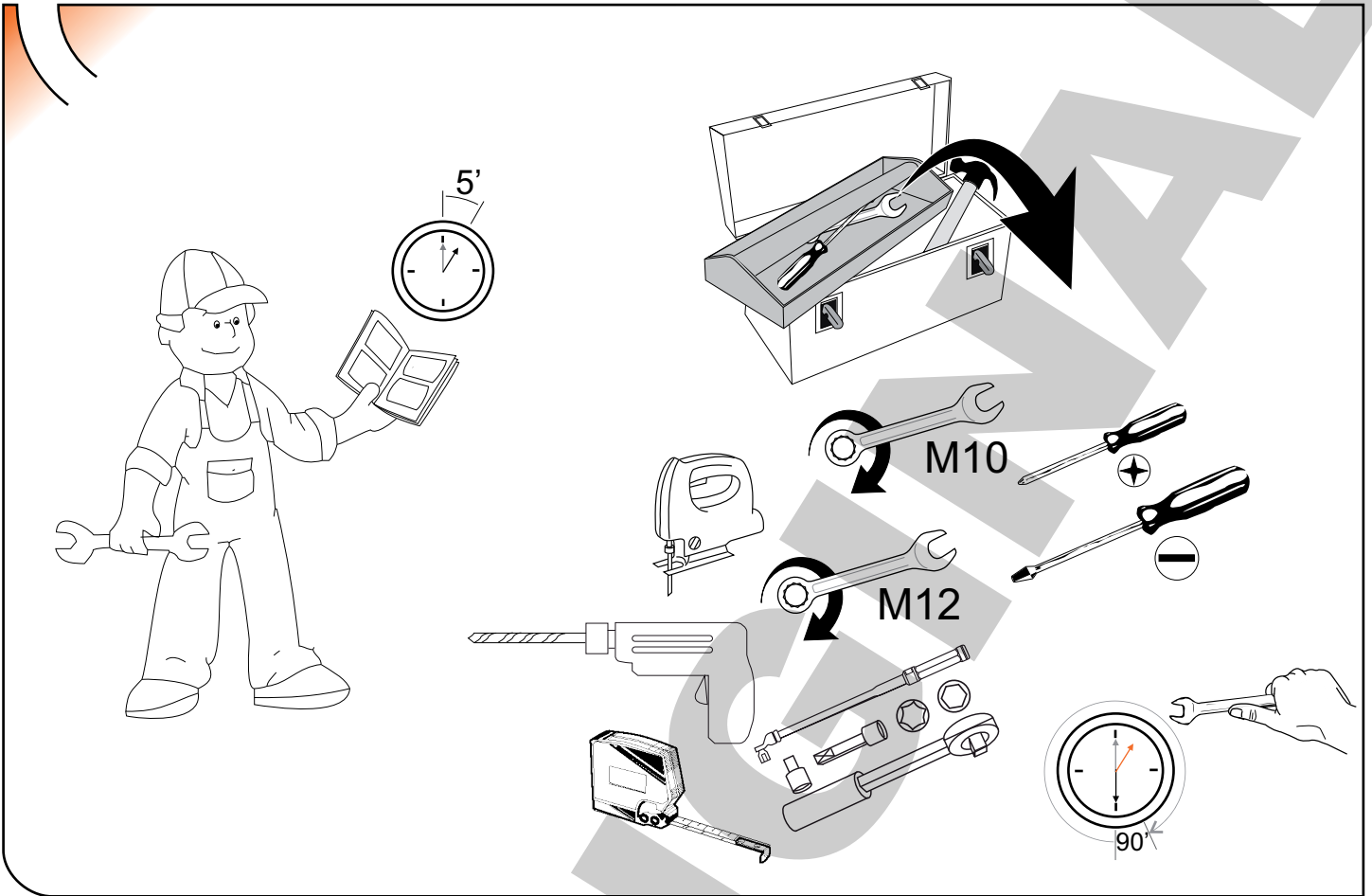

2

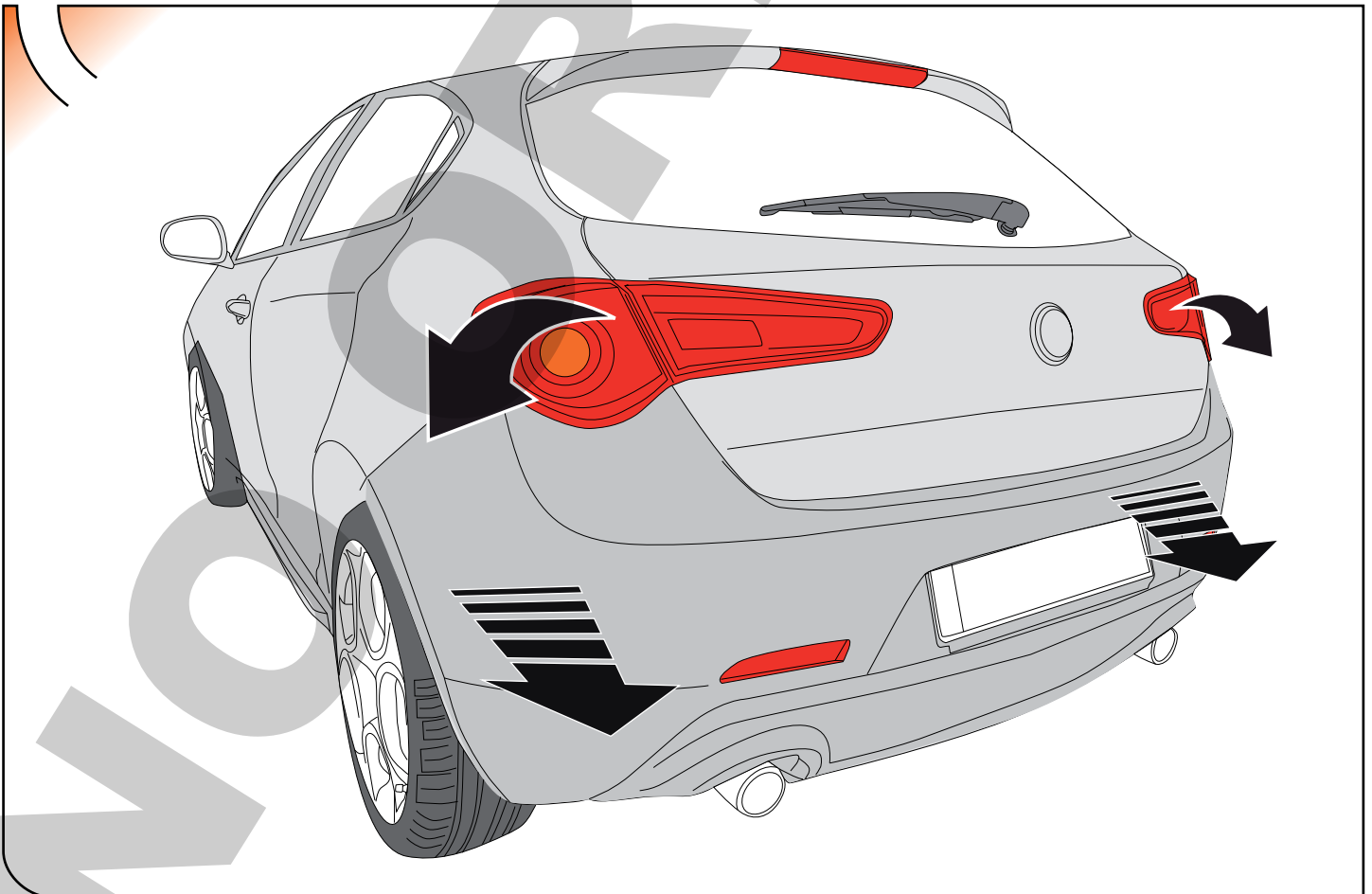

3

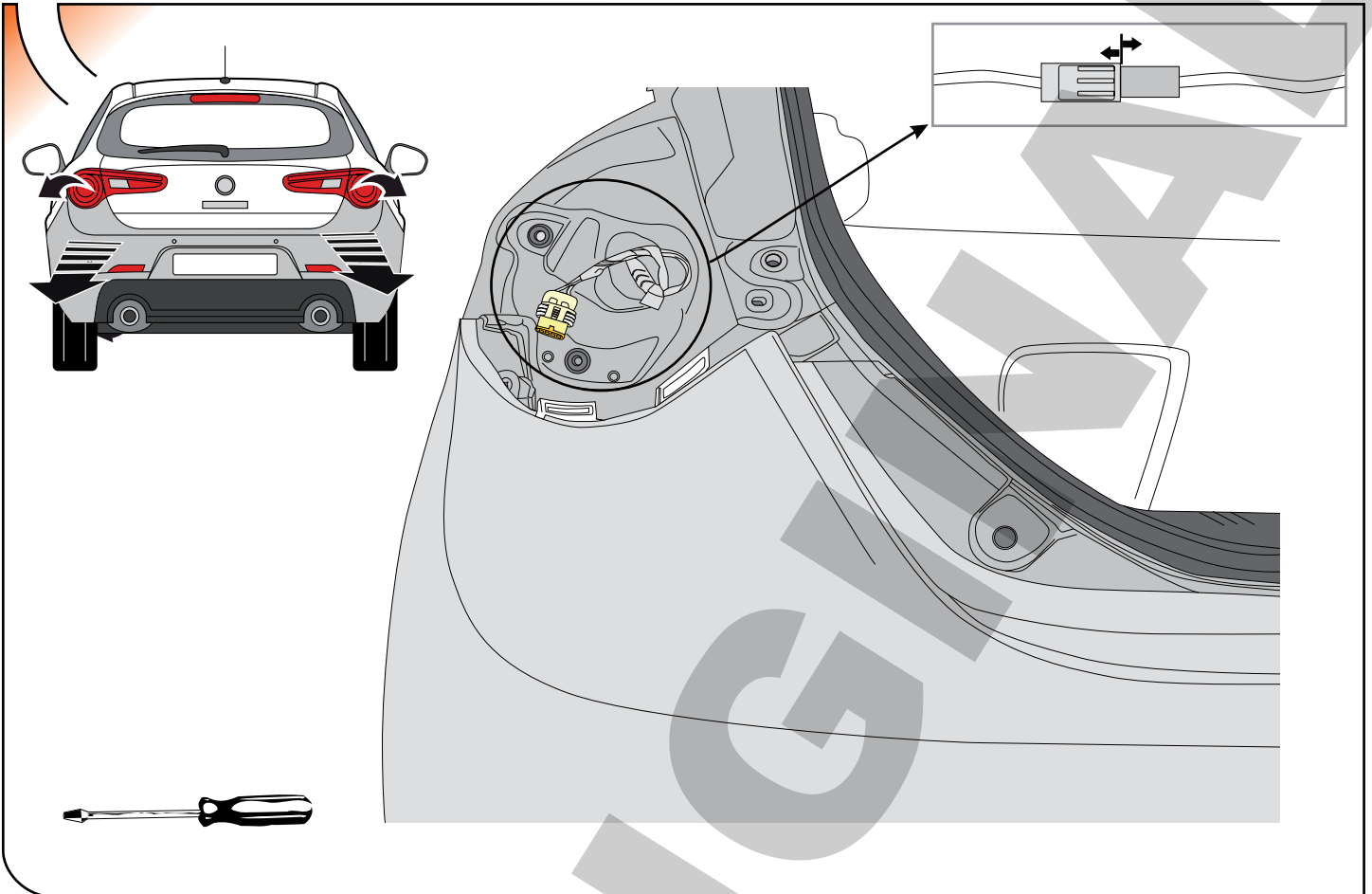

4

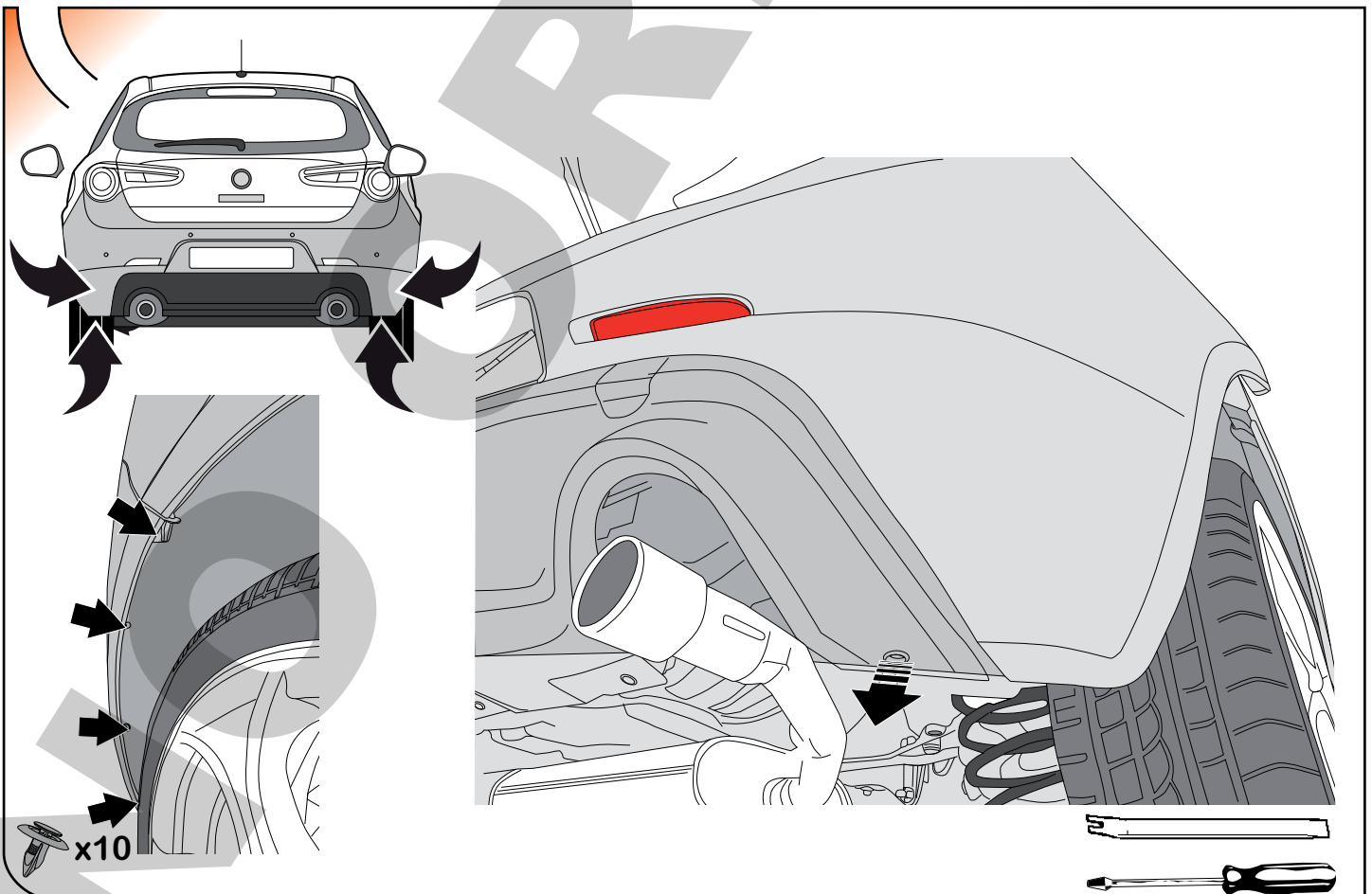



5

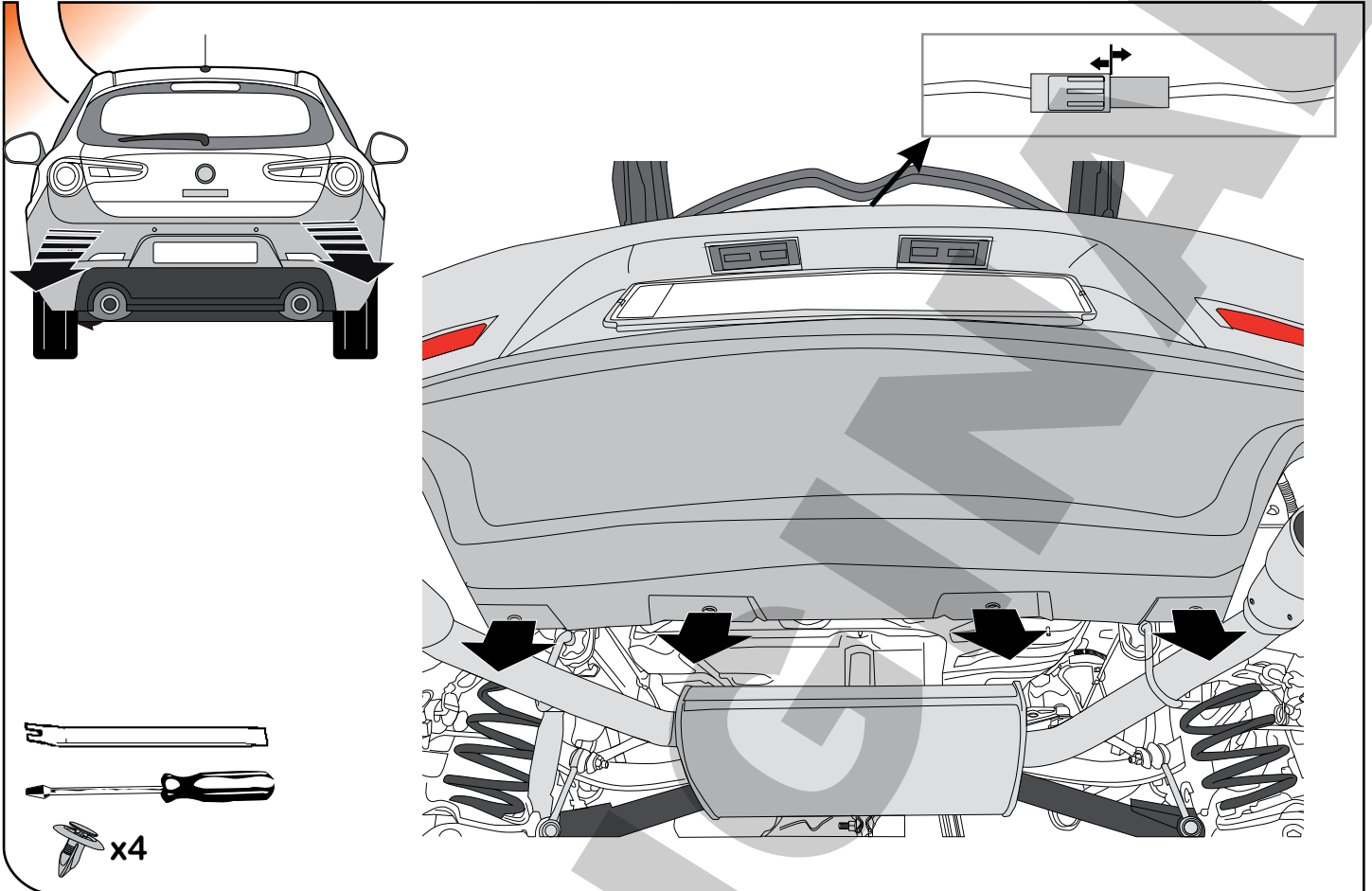

6

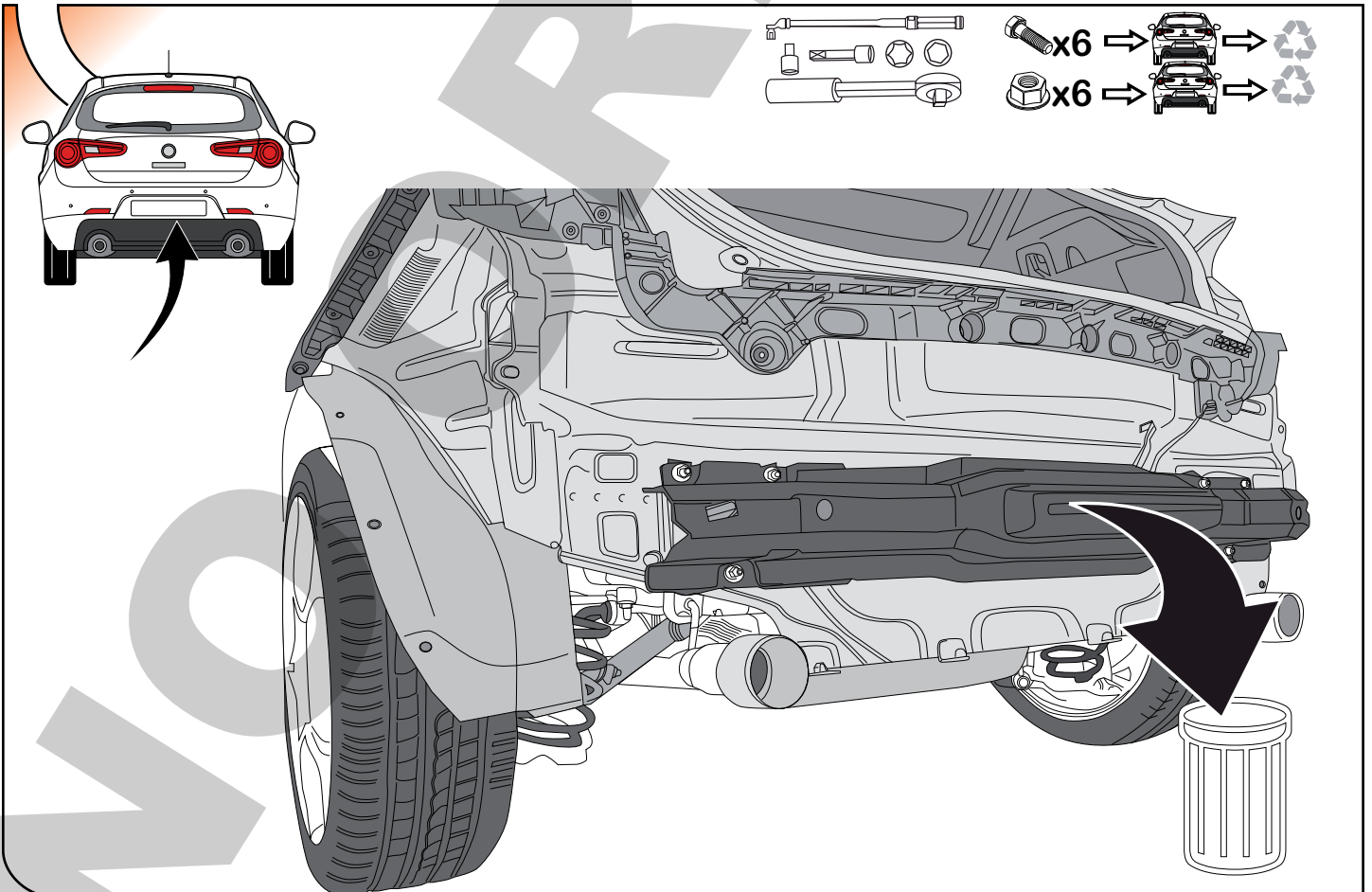



7

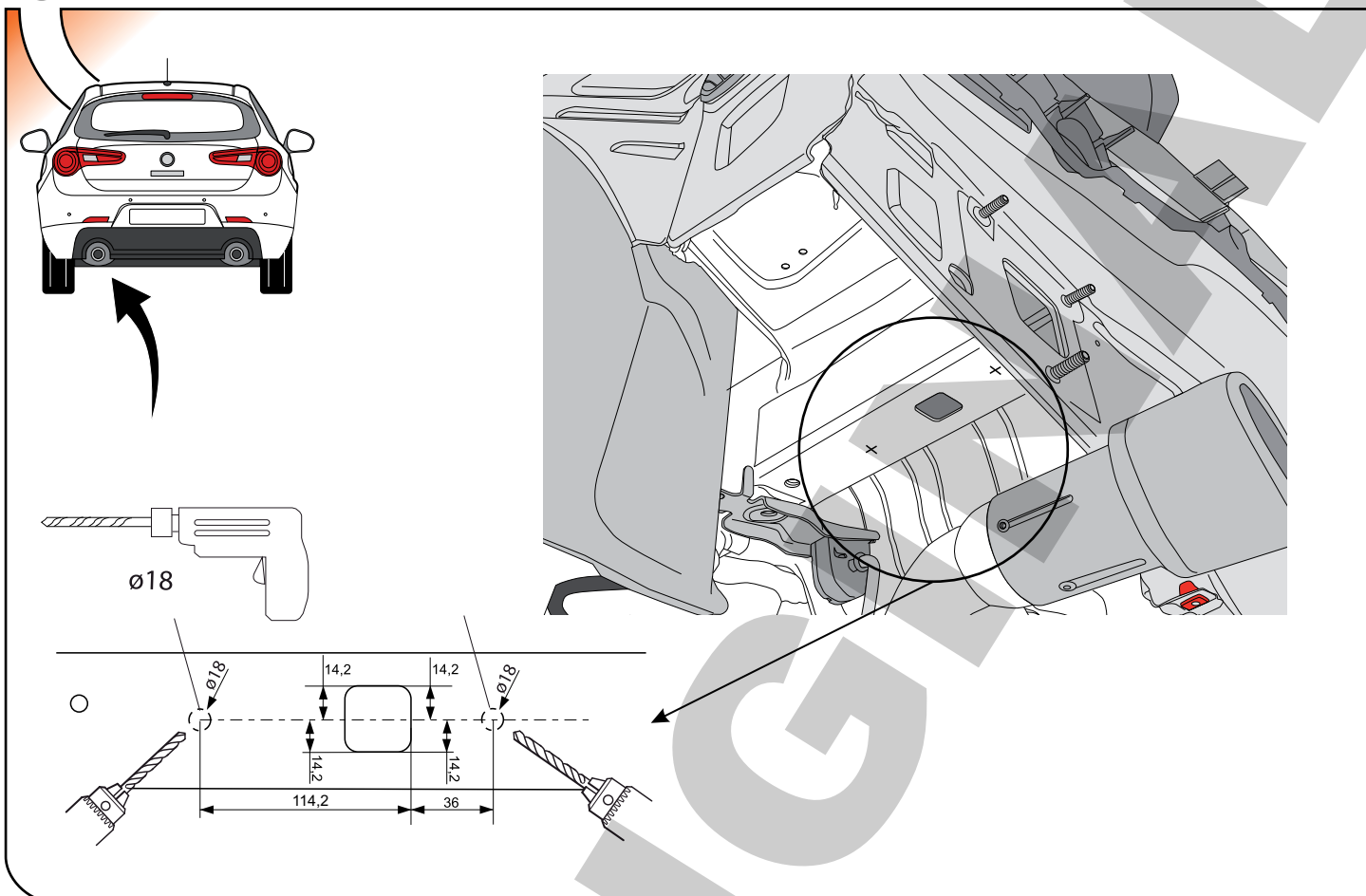

8

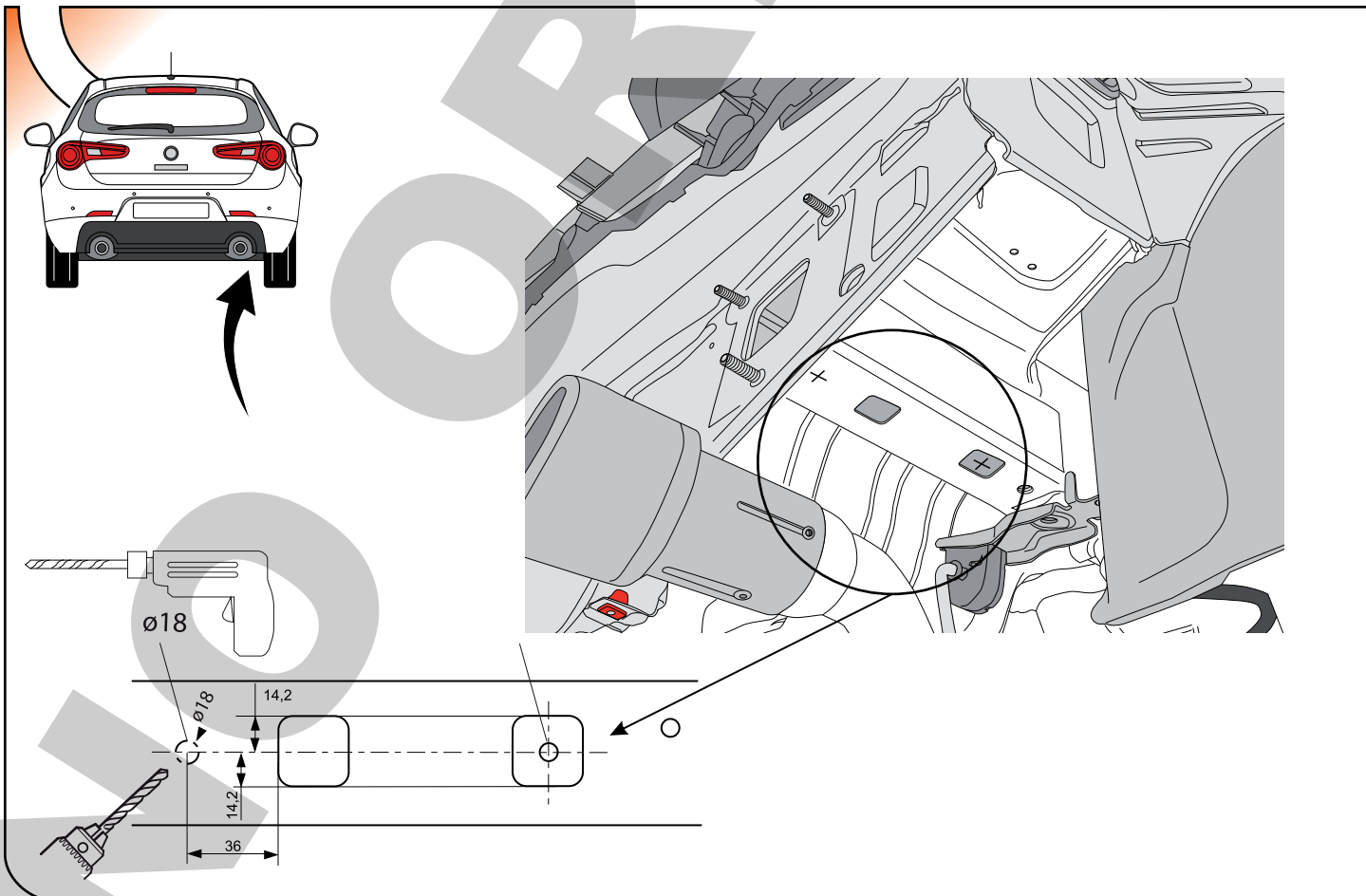

9

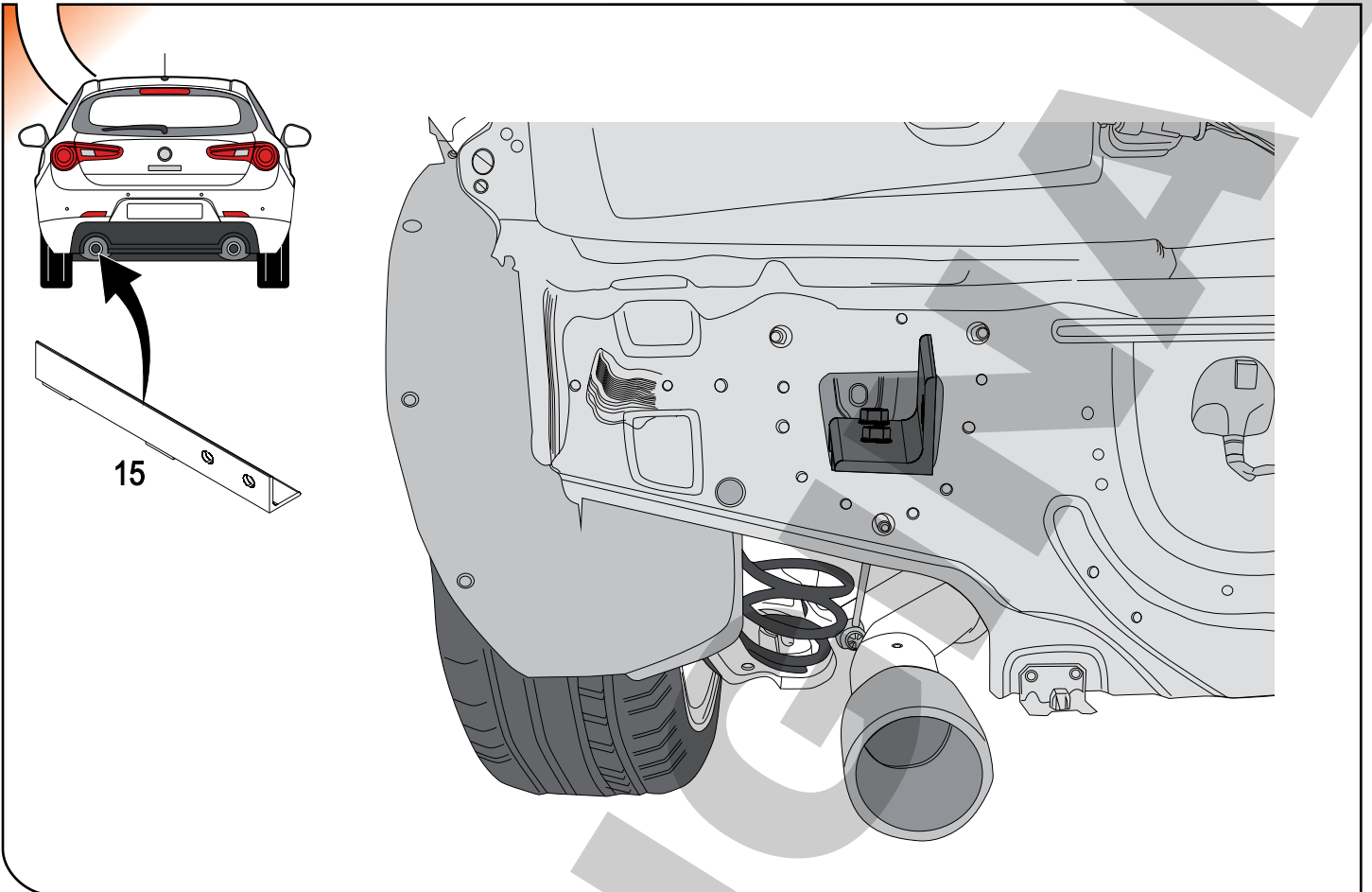

10

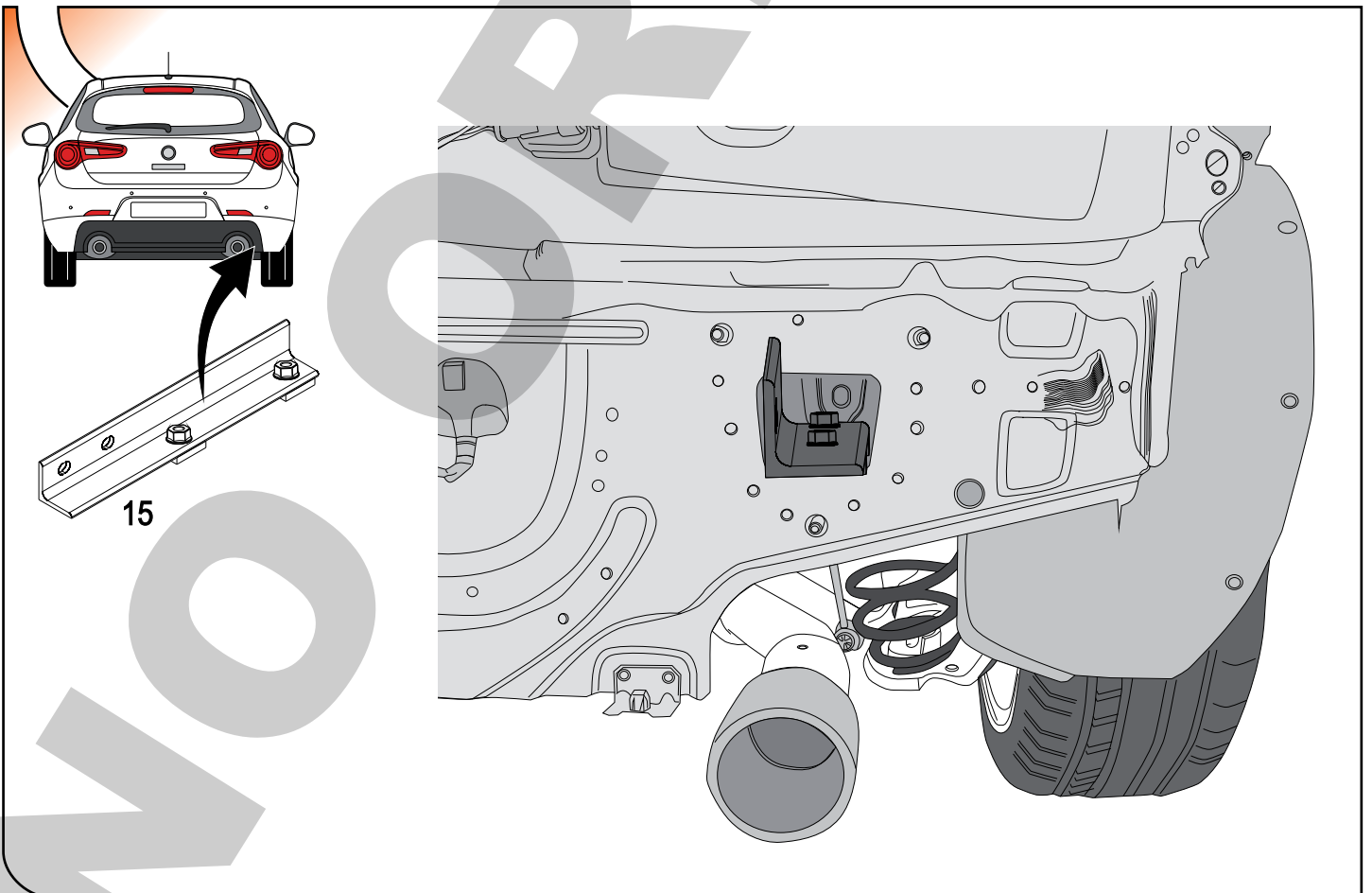

11

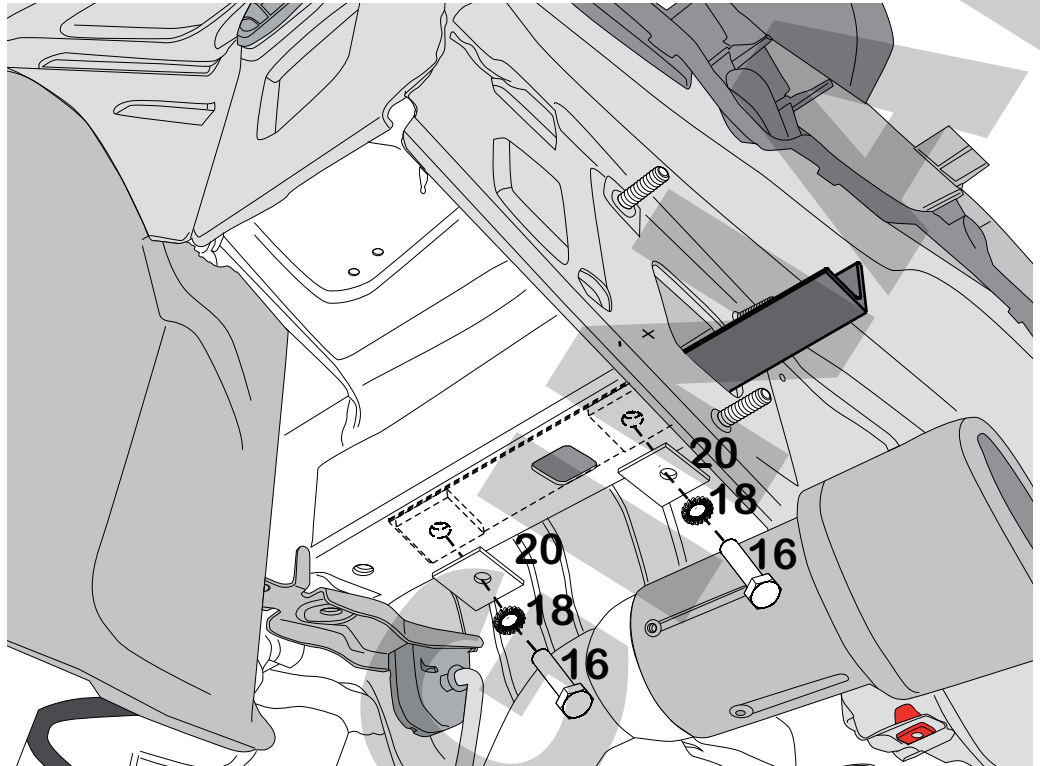
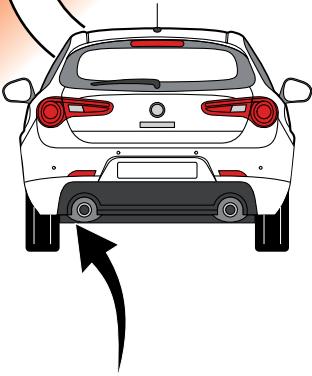

x2 (M10x35)

x2(Ø10)

50x50

12

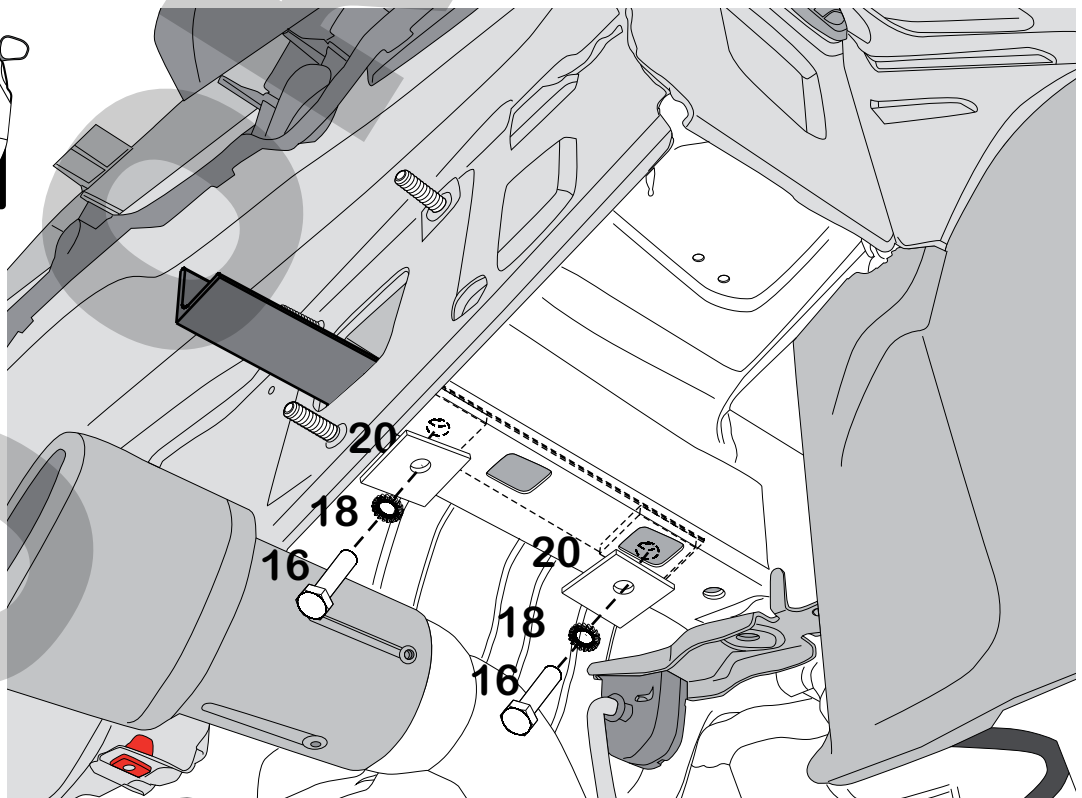
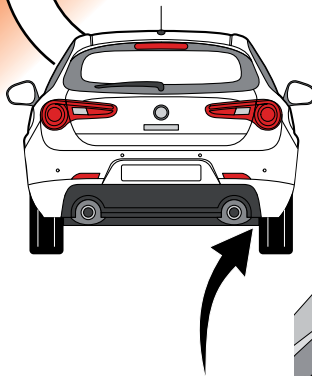

x2 (M10x35)

x2(Ø10)

50x50

13

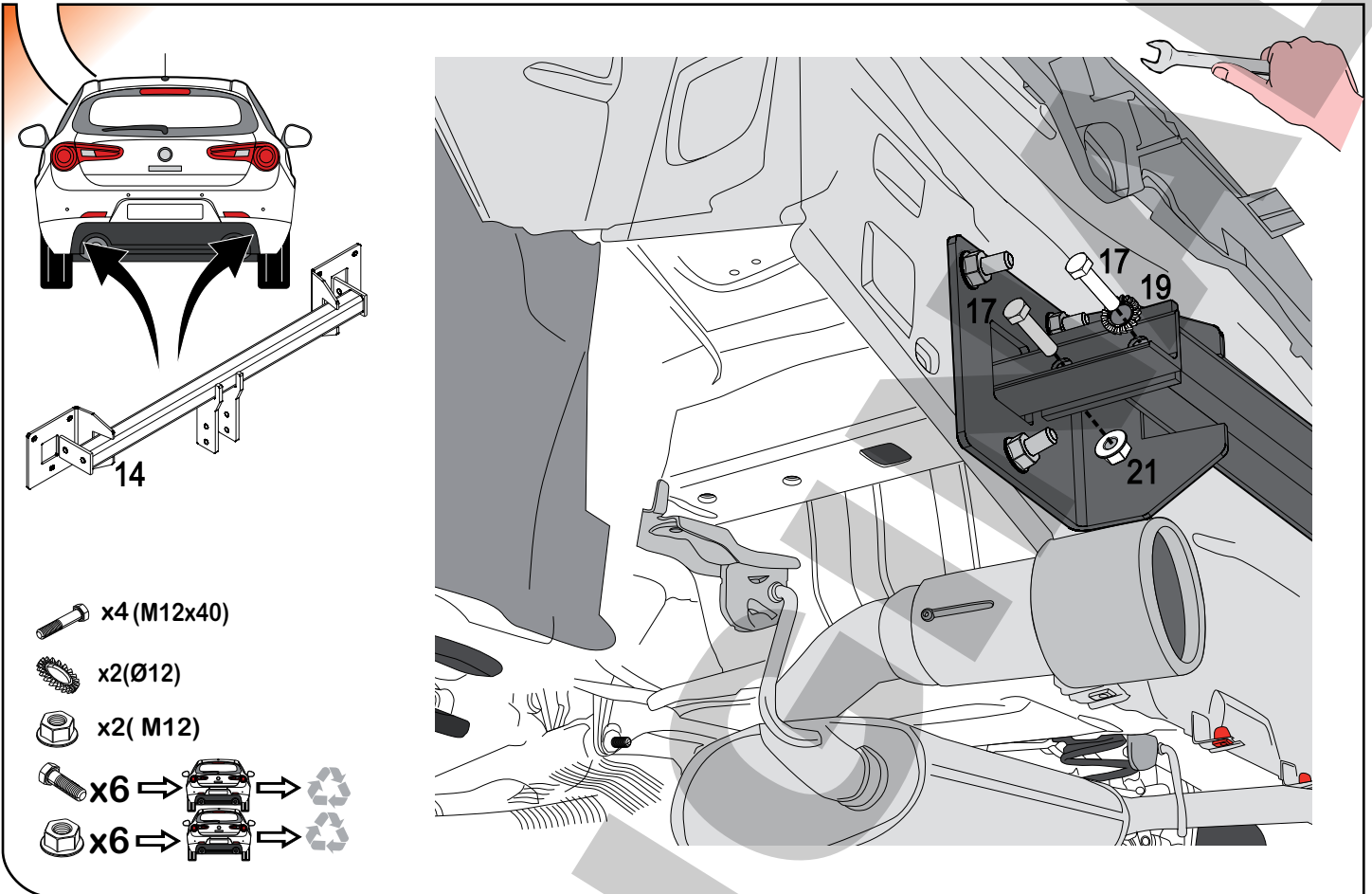

14

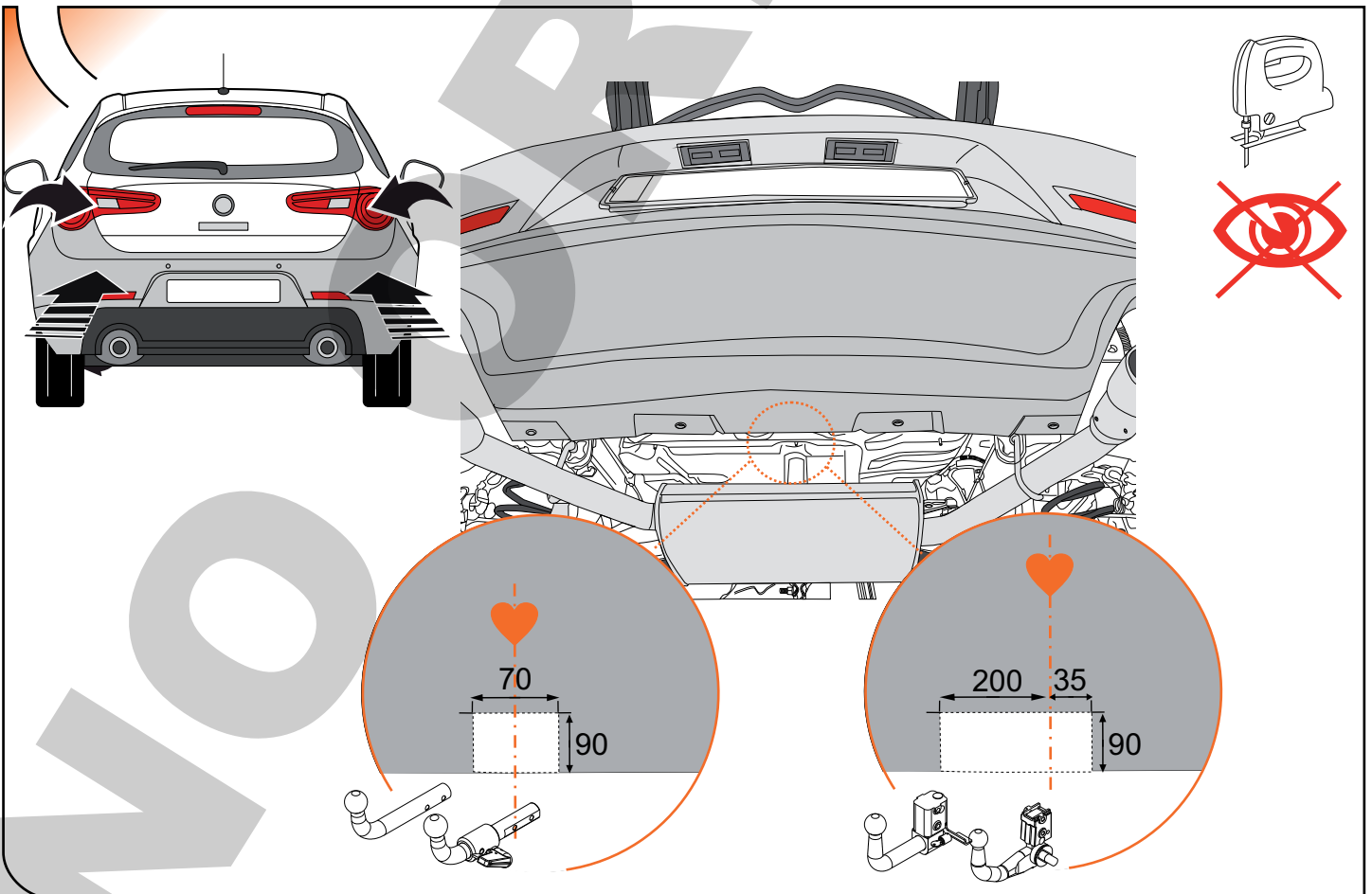

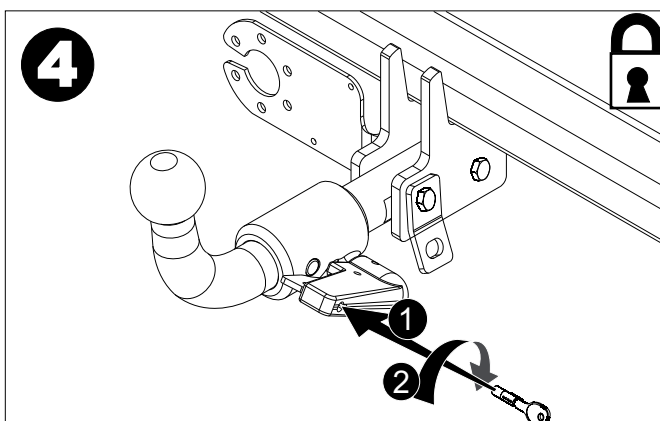
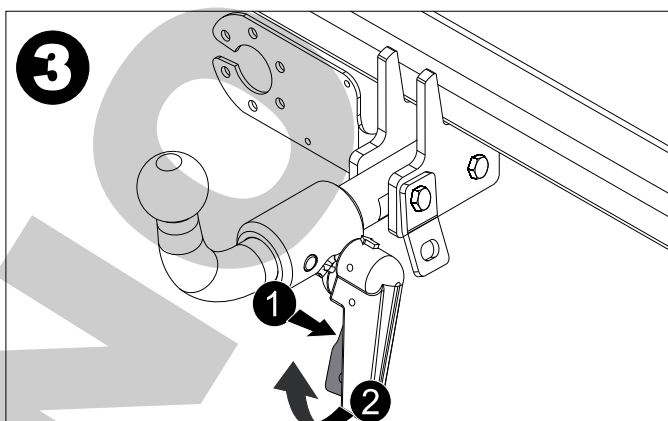
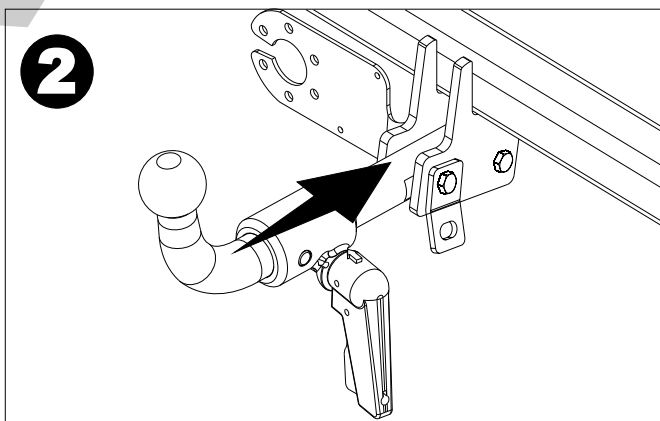
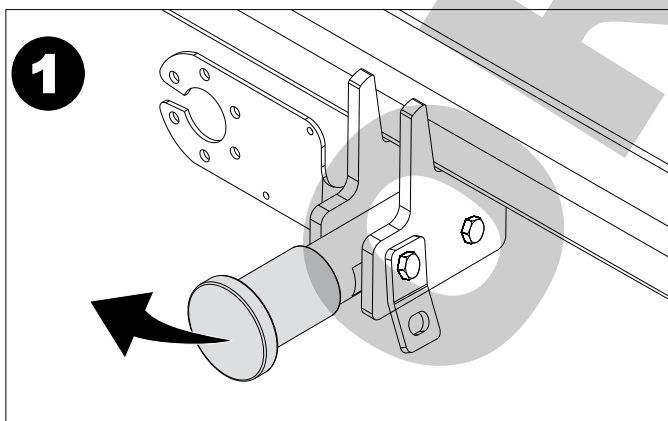
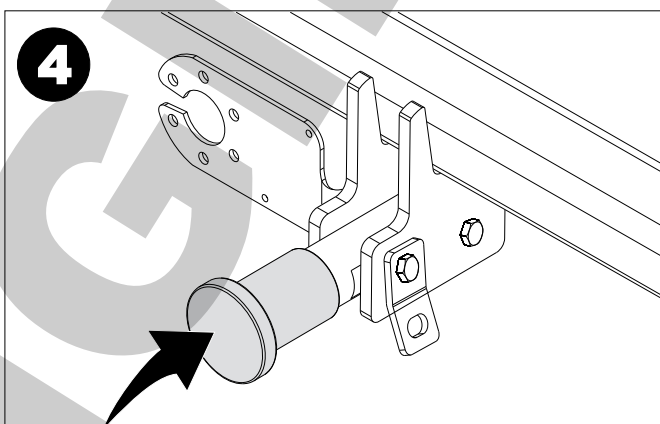
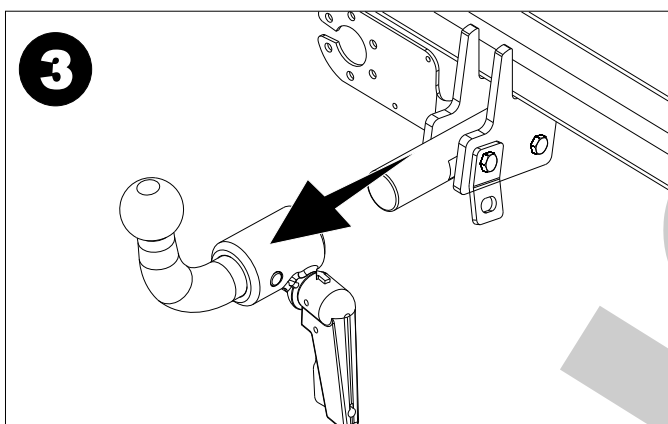
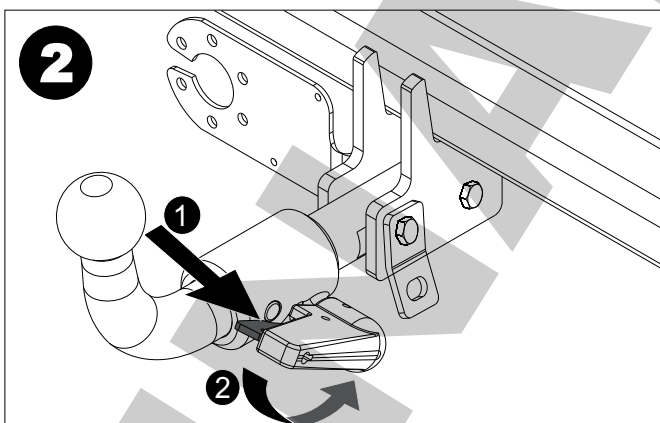
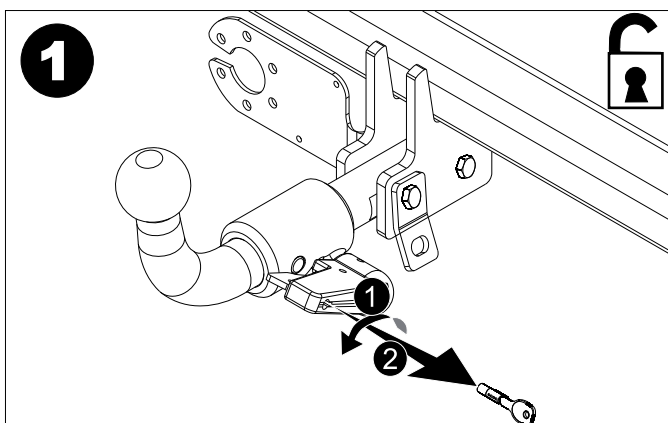



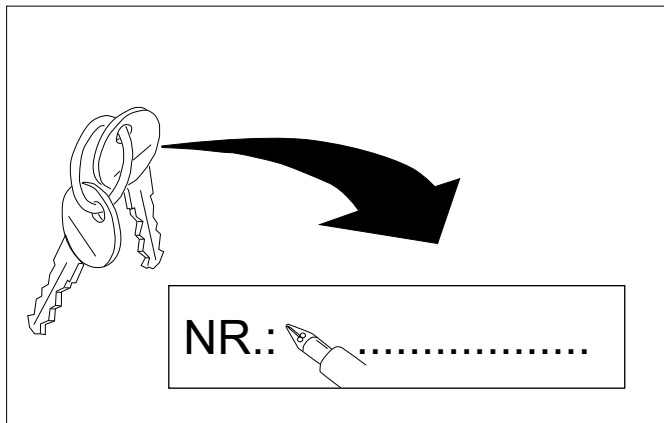
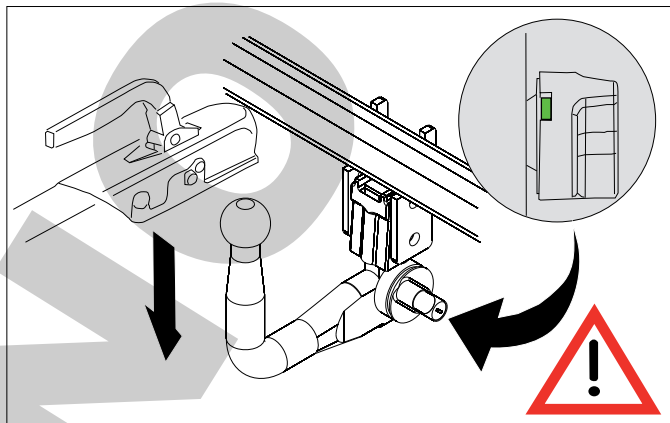
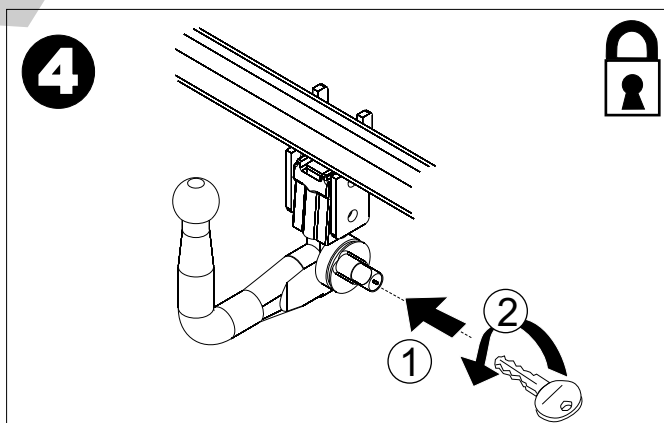
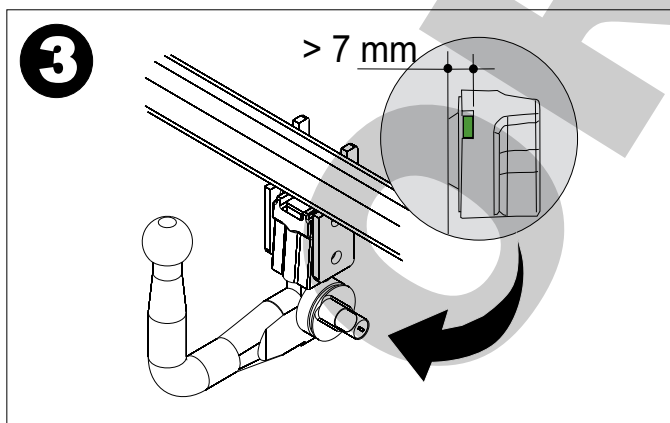
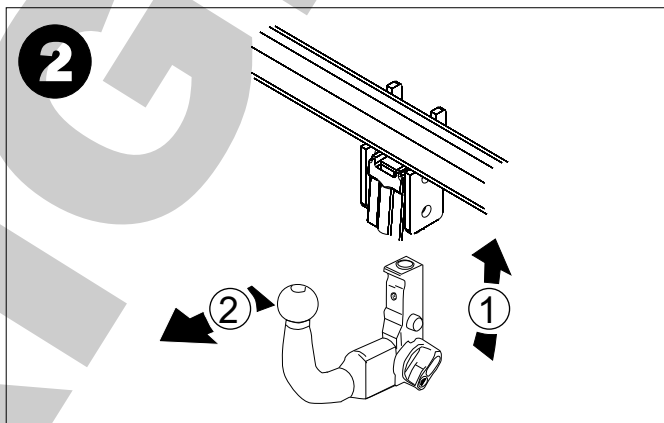
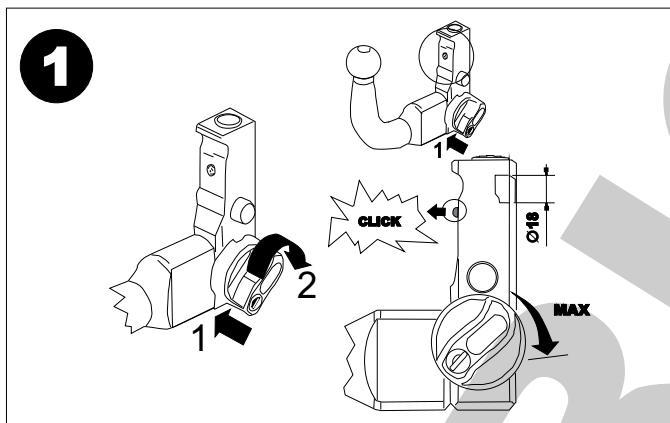
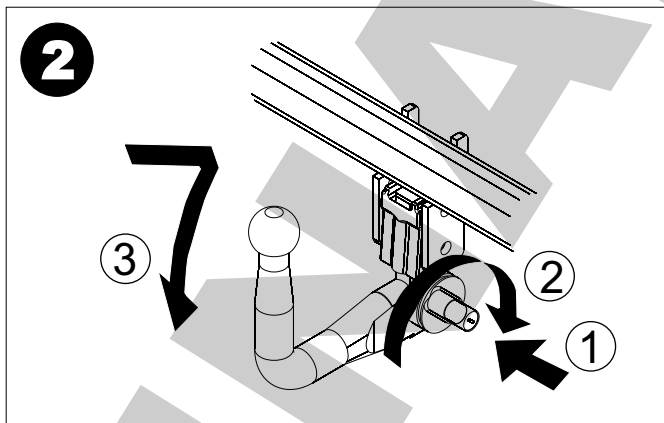
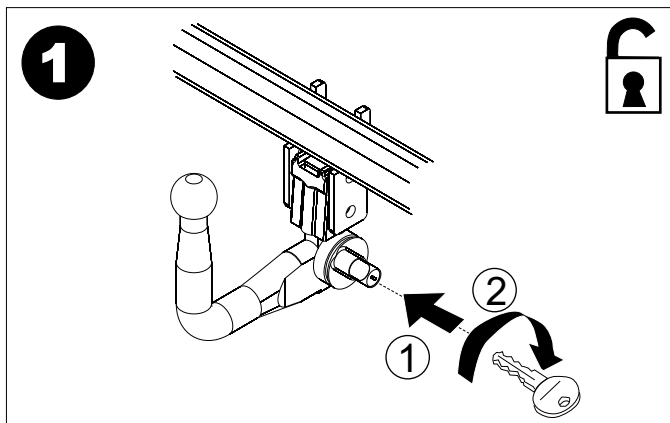



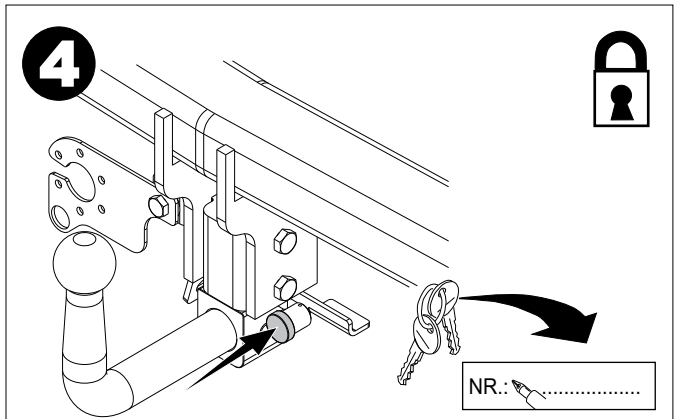
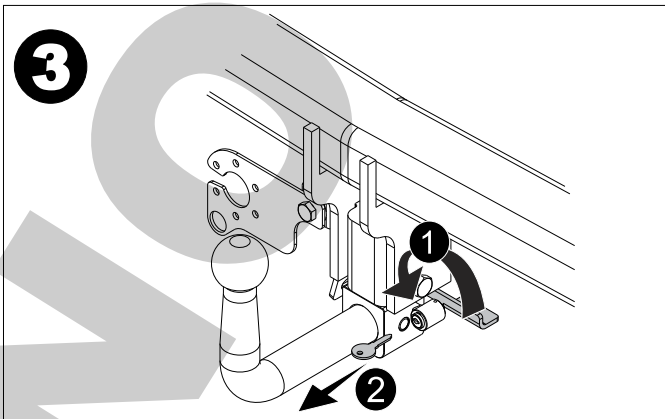
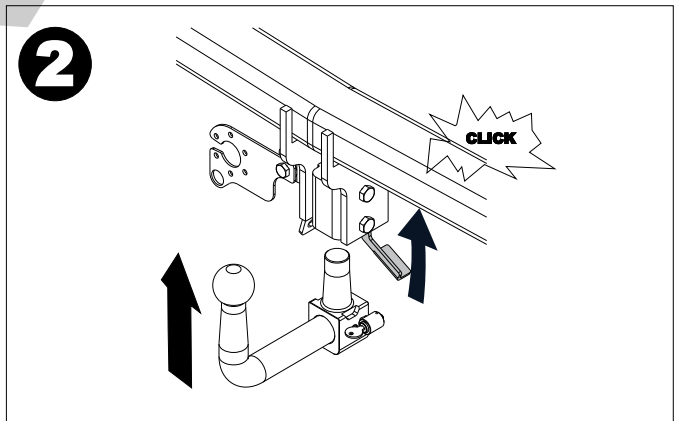
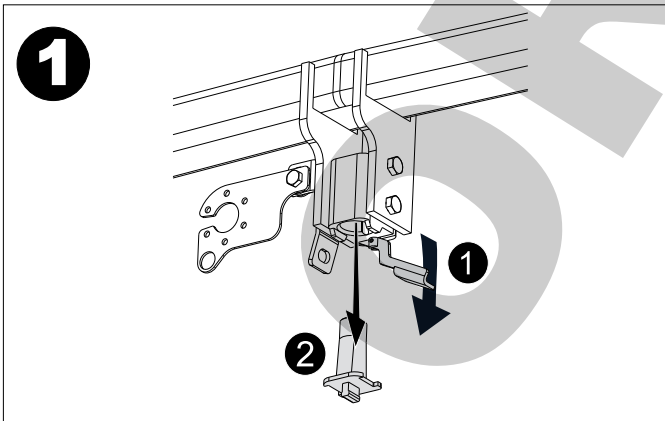
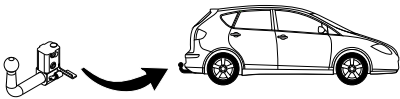
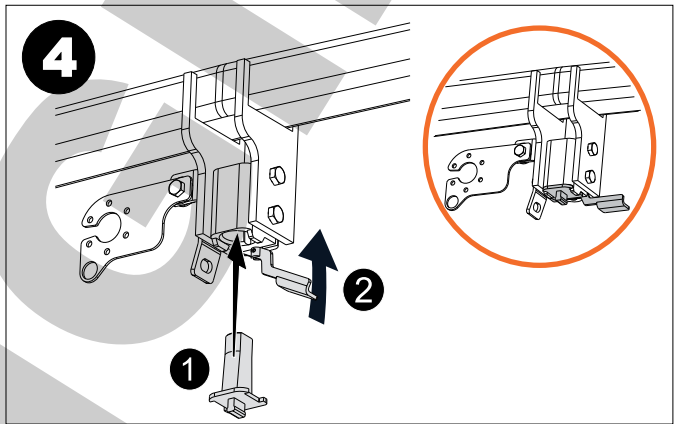
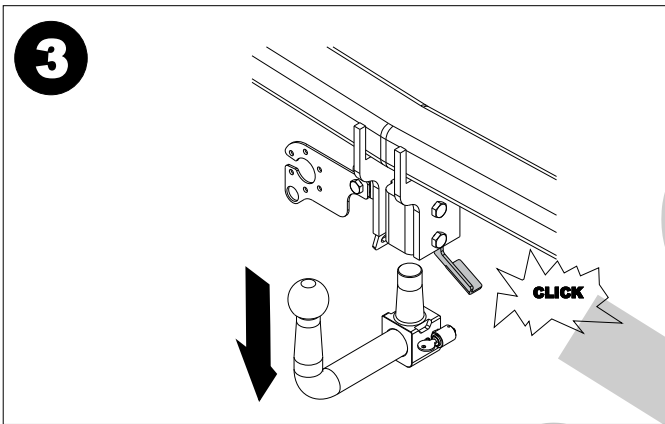
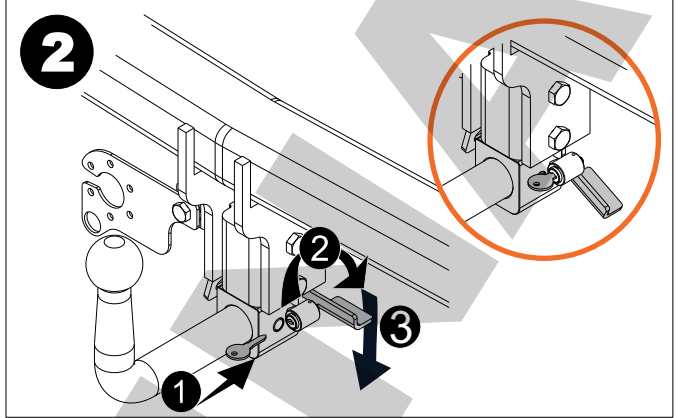
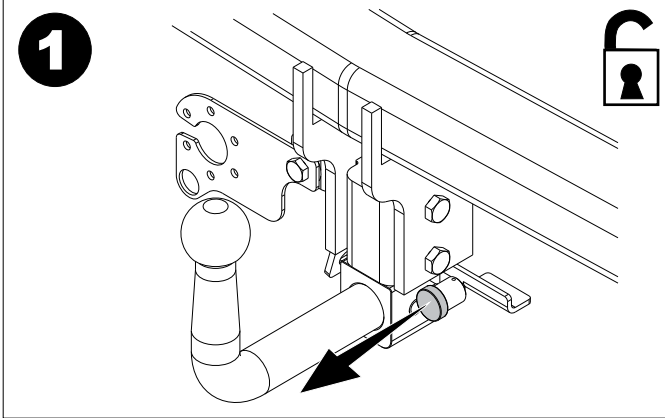
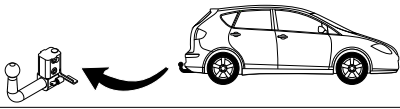

# CERTIFICADO DE MONTAJE

D./Dña. ....  
responsable técnico de la empresa .....  
domiciliada en .....,provincia de .....  
Calle ....., N° ....., teléfono .....  
dedicada a la actividad de .....  
con el N° de Reg. Industrial .....

## CERTIFICA

Que la mencionada empresa ha realizado la/s reforma/s consistente en: (1)  
Incorporación de dispositivo para remolcar, marca .....  
Valor "D" (2) .....kN. ,  
Valor "S" (2) .....kg. ,  
con una MMR C/F de .....kg,  
con N° de Identificación / Marca de Homologación .....

Tipificadas en el Real Decreto 736/1988 con el número (3) .....  
sobre el vehículo

Marca ....., Tipo .....  
Variante ....., Denominación Comercial .....  
Matrícula ..... y N° de Bastidor .....

de acuerdo con:

- La normativa vigente en materia de reformas de importancia en vehículos.
- Las condiciones del informe favorable, o en su caso, las normas del fabricante del vehículo aplicables a la/s reforma/s llevadas a cabo en él.
- El proyecto descrito de la/s reformas/s, adjunto al expediente.

**OBSERVACIONES:** .....

....., a ..... de ..... de 20.....

Firma y Sello

Fdo.: El Responsable Técnico

(1) Se describirán las operaciones básicas realizadas sobre el vehículo y se citarán los elementos y sistemas instalados.

(2) Sólo para enganches que cumplan la normativa 94/20/CE.

(3) Si el dispositivo para remolcar no cumple con la normativa 94/20/CE → poner "26"

Si el dispositivo para remolcar cumple con la normativa 94/20/CE → dejar en blanco y proceder a la anotación en la tarjeta ITV adjuntando el certificado de montaje del taller y el manual de instrucciones de montaje.

Indicaciones para rellenar el certificado al dorso,



Valor "D"

$$D = \text{Pag.1 kN}$$

Valor "S"

$$S = \text{Pag.1 kg}$$

MMR C/F

Pag.1

Nº de Identificación /  
Marca de Homologación

**ENGANCHES ARAGON**

CLASS:

APPROVAL NUMBER

e 13  00-0000

TYPE:  XXX

D-VALUE

D  kN

MAX. VERT. LOAD

S  kg

Tel: +34 976 45 71 30  
www.enganchesaragon.com

E  
I

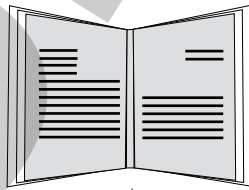

NL D GB A  
PL RU F TR  
CZ P GR

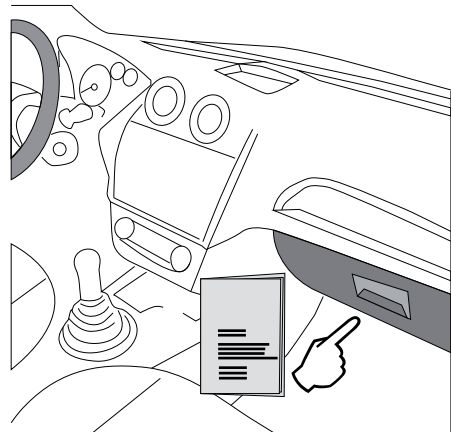
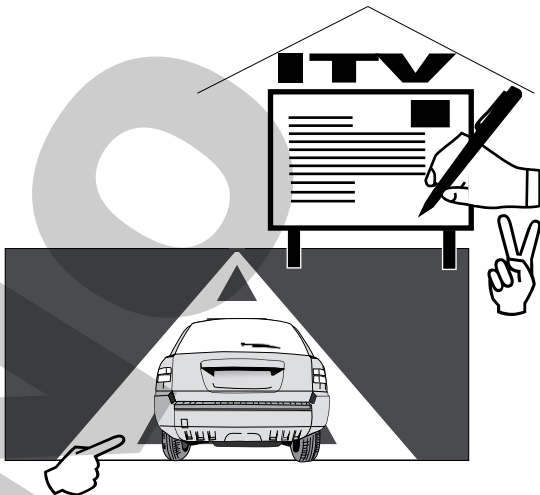

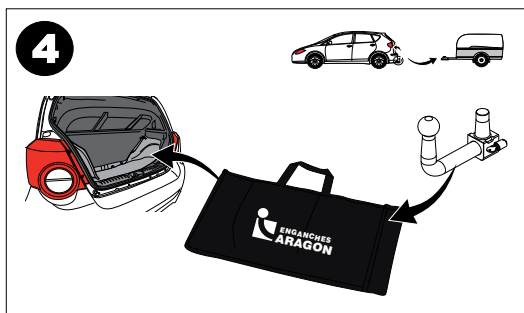
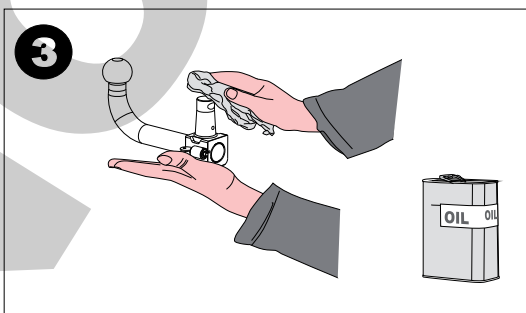
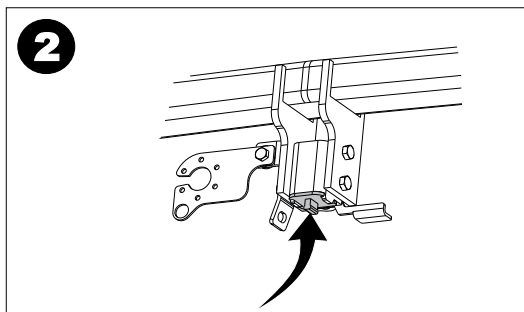
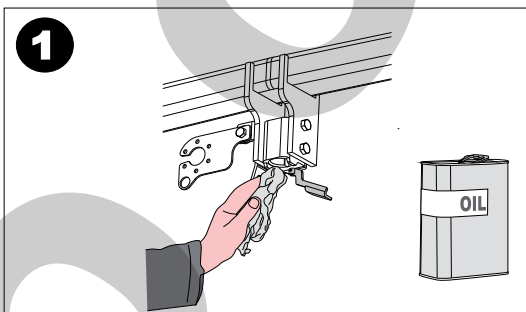
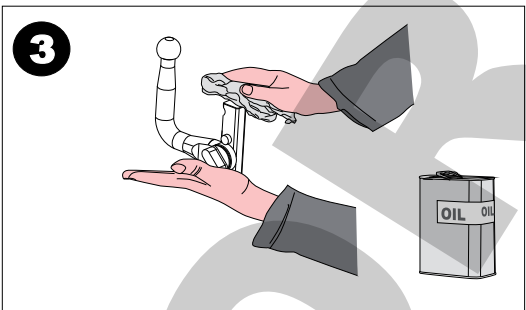
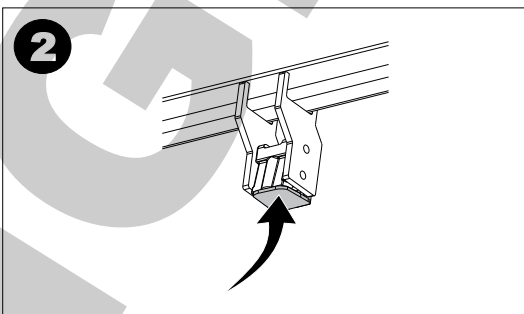
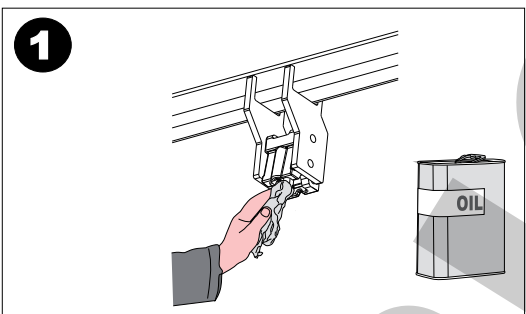
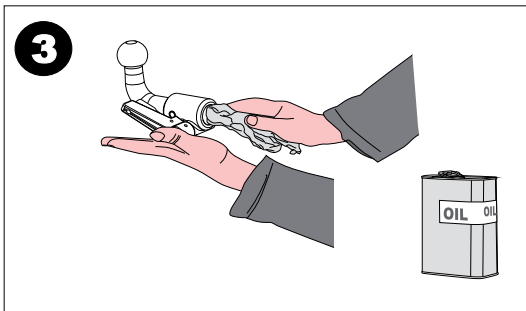
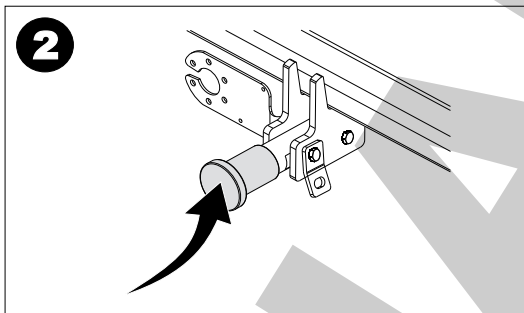
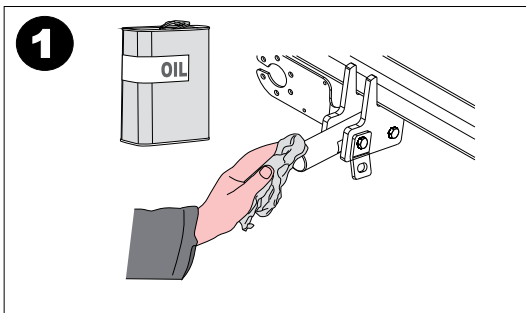

MANTENIMIENTO DE SISTEMAS EXTRAIBLES  
DETACHABLE SYSTEMS MAINTENANCE





E

ⓘ Dependiendo de la versión y el año, una parte del paragolpes puede ser necesariamente recortada.

La información proporcionada por nosotros para el recorte del paragolpes es sólo una ayuda no vinculante.

El recorte se sabrá correctamente durante el montaje, con el tamaño requerido.

GB

ⓘ Depending on car's version and year, part of the bumper need to be cut.

Information provided by us for the cutting of bumper is only a non binding help.

The cut will know properly during assembly with the required size.

F

ⓘ Selon la version et l'année du véhicule, une partie du parechoc peut être découpée.

L'information transmise pour la découpe est seulement une aide , à chacun de vérifier la découpe nécessaire.

La découpe se verra correctement durant le montage , aux dimensions requises.

I

ⓘ Dipendendo dalla versione e dell'anno, un pezzo del paraurti può essere tagliato.

L'informazione proporzionata da noi per il paraurti è solo un aiuto non vincolante.

Il taglio si saprà esattamente durante il montaggio col formato necessario.

D

ⓘ Je nach Ausstattungsvariante und Baujahr kann ein Ausschnitt des Stoßfängers zur Nachrüstung erforderlich sein.

Von uns gemachte Angaben zum Ausschnitt des Stoßfängers sind nur eine unverbindliche Hilfestellung.

Der Ausschnitt ist fachgerecht im Zuge der Montage auf die erforderliche Größe vorzunehmen.

RU

ⓘ В зависимости от модели и года выпуска возможно потребуется сделать вырез на бампере.

Предоставляемая нами информация относительно выреза на бампере носит вспомогательный характер, но не является обязательной. Окончательные размеры выреза на бампере станут известны во время процесса установки.

**TR**

Enganches Aragon firması tüm ürünlerine (Çeki Topuzu Sistemleri) teslim tarihinden itibaren iki (2) yıl garanti vermektedir. Bu garanti, Avrupa Birliği tarafından verilen tarifname 1999/44/CE ve 23/2003 kanununa göre sahte ürünlerle değiştirilmesi halinde sınırlandırılmış ve de hasara ve zarara uğrama durumlarında hiçbir şekilde geçerli değildir.

ENGANCHES ARAGON Firması tarafından imal edilen Çeki Sistemleri markasına göre araçlara monte edilebilmektedir.

Çeki Topuzu Sistemlerimiz üzerindeki herhangi bir değişiklik yapmak yasaktır. Bu şartın ihlalinde (e) Avrupa Birliği garantisi ve ürün garantisi geçerliliğini kaybetmektedir.

**GR**

Η Enganches Aragon προσφέρει εγγύηση 2 ετών για τα προϊόντα της, με έναρξη την ημερομηνία παράδοσης των προϊόντων της, σύμφωνα με την οδηγία της Ε.Ε. 1999/44/CE τον νόμο 23/2003. Η υποχρέωση που πηγάζει για την ENGANCHES ARAGON από την εν λόγω εγγύηση περιορίζεται στην αντικατάσταση των ελαττωματικών προϊόντων και σε καμία περίπτωση δεν επεκτείνεται σε άλλες ζημιές ή επακόλουθες βλάβες.

Οι κοτσαδόροι που κατασκευάζονται από την ENGANCHES ARAGON, ταιριάζουν στην αναφερόμενη μάρκα αυτοκινήτου για την οποία προορίζονται.

Απαγορεύεται να κάνετε οποιαδήποτε τροποποίηση στους κοτσαδόρους μας. Στην περίπτωση που κάτι τέτοιο συμβεί αυτό ακυρώνει την εγγύηση του προϊόντος.

**P**

A firma Enganches Aragon, oferece garantia dos seus produtos por um período de dois anos a partir da data de entrega conforme o disposto na directiva 1999/44/CE e Decreto-lei 23/2003. Esta garantia está limitada à substituição de marcadoria defeituosa, não sendo passível de qualquer indemnização por parte do adquirente.

Os engates de reboque fabricados por esta firma são exclusivos e apropriados a cada modelo das diferentes marcas para as quais fabrica.

É expressamente proibida toda e qualquer modificação ou transformação da mercadoria, caso no qual qualquer destas infracções dará lugar à anulação da homologação e garantia dos mesmos.

**RU**

Производители фаркопов «Энганчес Арагон» предоставляют гарантию на свои изделия сроком на два года с момента доставки, согласно Распоряжению Европейского Союза 1999/44 и Закону 23/2003, при этом замена производится только в случае бракованного товара и не распространяется на причиненные повреждения и неполадки.

Фаркопы, изготовленные на фабрике «Энганчес Арагон», адаптируются к марке автомобиля.

Запрещается изменять или модифицировать любой из наших товаров. Несоблюдение данного требования приведет к прекращению гарантии на товар и к его несоответствию стандартам качества.

**PL**

Enganches Aragon oferuje dwuletnią gwarancję na swoje produkty od daty dostarczenia, zgodnie z europejską dyrektywą 1999/44/CE i prawem 23/2003. Gwarancja obejmuje wyłącznie wymianę wadliwych produktów. Gwarancja nie może być poszerzona o wypłatę odszkodowania czy powstałe szkody.

Hak holowniczy Enganches Aragon odpowiedni dla marki samochodu.

Zabronione jest dokonywanie jakichkolwiek modyfikacji naszych haków holowniczych. Niezastosowanie się spowoduje utratę gwarancji.

**CZ**

Firma Enganches \*\*Aragon\*\* poskytuje na své výrobky záruku po dobu 2 měsíců od data jejich dodání. Ve smyslu znění evropské směrnice 1999/44/CE a zákona 23/2003 je záruka omezena na výměnu vadných výrobků a v žádném případě se záruka nevztahuje na náhradu vzniklé škody, nebo ublížení.

Tažné zařízení vyrobené u ENGANCHES ARAGON vhodné pro tuto značku vozidla.

Na našich tažných zařízeních je zakázáno provádět jakékoliv úpravy. Nespění této podmínky ruší schválení a záruku na výrobek.

**A**

تقدم إنكنشيس أرغون مدة سنتين كضمان على منتجاتها ابتداء من تاريخ التسليم طبقا لما جاء في توجيهات الاتحاد الأوروبي 44/1999 والقانون رقم 23/2003 وتخص حصريا البضاعة التي بها عيوب أو أخطاء. ولا تمنح أبدا في حالات التلف أو الإستخدام الغير الجيد.

صنع المنتج من طرف إنكنشيس أرغون وهو موافق لنوع هذه السيارة .

يمنع منعاً كلياً أي تغيير أو تحويل قد تعرض لها بضاعتنا. عدم التقيد بذلك يلغي شروط الضمان بالكامل.



ENGANCHES Y REMOLQUES ARAGÓN S.L.



Polígono Industrial Malpica, Calle B, Parcela 77

Tel. 00 34 976 45 71 30 | 00 34 902 45 71 30

Fax 00 34 976 45 71 31

E- 50057 Zaragoza (España)

E-mail: [eng@enganchesaragon.com](mailto:eng@enganchesaragon.com)

[www.enganchesaragon.com](http://www.enganchesaragon.com)

